

2009 Event Planning Guide



VIRGINIA SPORTS HALL OF FAME & MUSEUM

206 High Street, Olde Towne Portsmouth

Tel (757) 393-8031 ext. 23 | Fax (757) 393-8288 | www.vshfm.com/facilities

The perfect setting for inspiring parties & events!

No matter the event, the Virginia Sports Hall of Fame & Museum provides a state-of-the-art facility guaranteed to entertain and make your special event an affair to remember. From meetings, retreats and fundraisers, to banquets, reunions and holiday parties, our dedicated staff turns event planning into a stress-free occasion for you!

The Virginia Sports Hall of Fame is one of only 16 state sports halls of fame in the nation. This sparkling, two-story building features multiple spaces for entertaining, surrounded by exciting exhibits and interactive play areas on NASCAR, football, golf, health & wellness, media, & college sports.

The Hall of Fame is conveniently located in Olde Towne Portsmouth, just across the Elizabeth River from Downtown Norfolk and one block from the Renaissance Portsmouth Hotel.

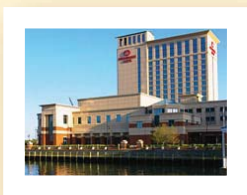

RENAISSANCE PORTSMOUTH HOTEL



Sports Gallery

Located on the first level.

Capacity **300 Standing**
 208 Theater-style
 160 Banquet
 120 Banquet
 with dance floor

Ideal for seated dinners, receptions, large meetings & trade shows. The Sports Gallery is a **spacious 2,775 sq.ft.** to accommodate your group's needs and make your event one to remember.

Rental of the Sports Gallery includes access to an **outdoor patio** suitable for outdoor seating and even tents. **Internet access, portable public address system, risers & podium** are also available at no additional cost. The Sports Gallery is conveniently located adjacent to the catering kitchen.

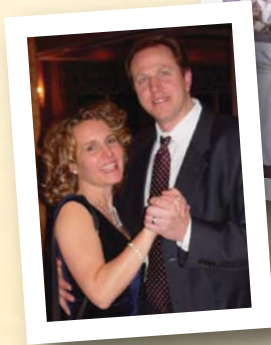
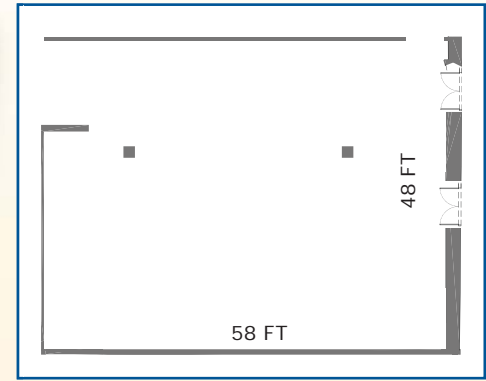

G. Robert Aston Boardroom

Located on the second level.

Capacity 30

With plush **conference-style seating**, the boardroom is a professional setting ideal for meetings, training sessions & luncheons. Complete with **state-of-the-art audio-visual equipment** and internet access, along with a **wet bar**.

Because we know you are busy, rental of the boardroom **includes admission tickets**, enabling your group to enjoy the Hall of Fame on the day of your meeting or on a later date (*within 90 days*).

Make a lasting impression by conducting your next meeting in the Hall of Fame's handsome & comfortable boardroom.

BOARDROOM FLOOR PLAN

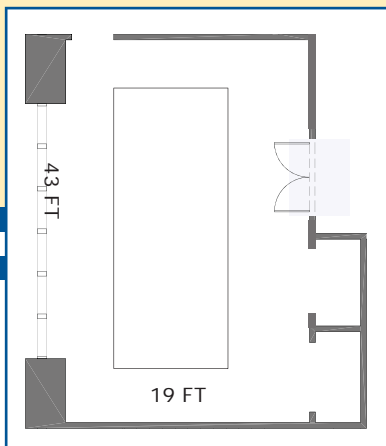

Cox Communications Digital Theater

Located on the first level.

Capacity 125

Enjoy the region's largest **high-definition** video screen (16 ft) in the Cox Communications Digital Theater. Complete with **surround-sound**, the theater is ideal for multimedia presentations, lectures, training programs, musical events & to watch the big game in a way your group will enjoy & never forget!

The theater features an **elevated stage & podium, and is wired for DVD, VHS, cable, computer and even video games!** It's a great location for live performances by small ensembles and choral groups of 50 or fewer.



THEATER FLOOR PLAN

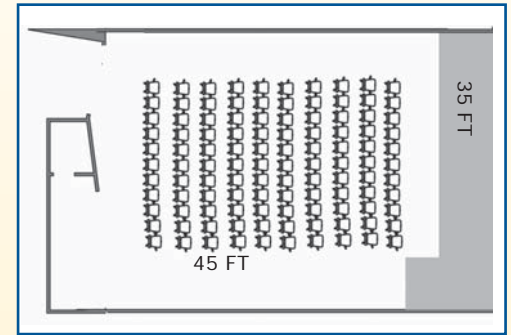

Norfolk & Portsmouth Sports Club Classrooms

Located on the first level.

Capacity 75 Standing
60 Theater-style
40 Banquet

An extremely versatile room, comfortable for receptions, luncheons, classroom-style workshops & small parties! The room **can be divided into two smaller spaces**, perfect for meeting break-out sessions & intimate gatherings.

A quiet setting perfect for meetings, the classroom is equipped with a **built-in projector** for presentations on PowerPoint & DVD.



CLASSROOMS FLOOR PLAN

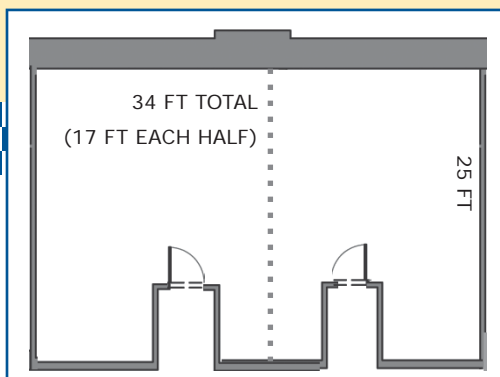

How to Begin Planning Your Party!

For more information or to book your event at the Virginia Sports Hall of Fame, contact the Special Events department at **757-393-8031 ext. 23** or events@vshfm.com.

The Hall of Fame is available seven days per week, day or evening, except on the following holidays: Fourth of July, Thanksgiving Day, Christmas Eve, Christmas Day, New Year's Eve and New Year's Day.

Pricing for facility rentals is done on a per-event basis, and is determined by duration of the event, number of guests and services required. Discounts are

available for Hall of Fame members, City of Portsmouth departments and non-profit organizations.

Your event must be booked at least two weeks in advance. A 50% deposit, along with a signed contract, is required to reserve a date.

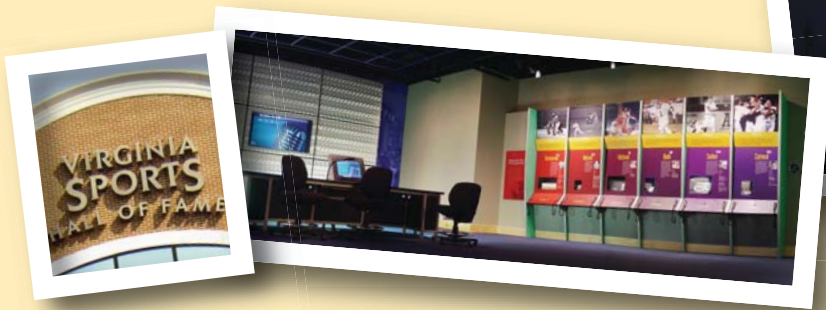

Floor Plans

FIRST FLOOR

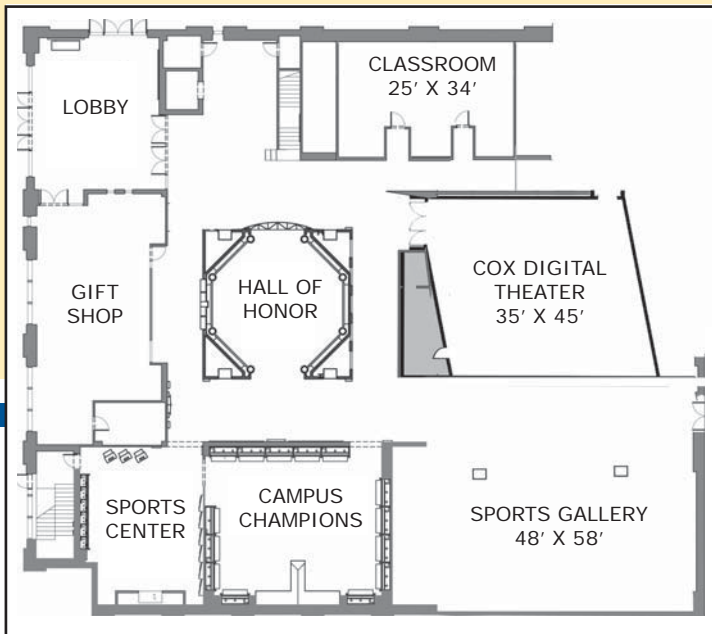

SECOND FLOOR

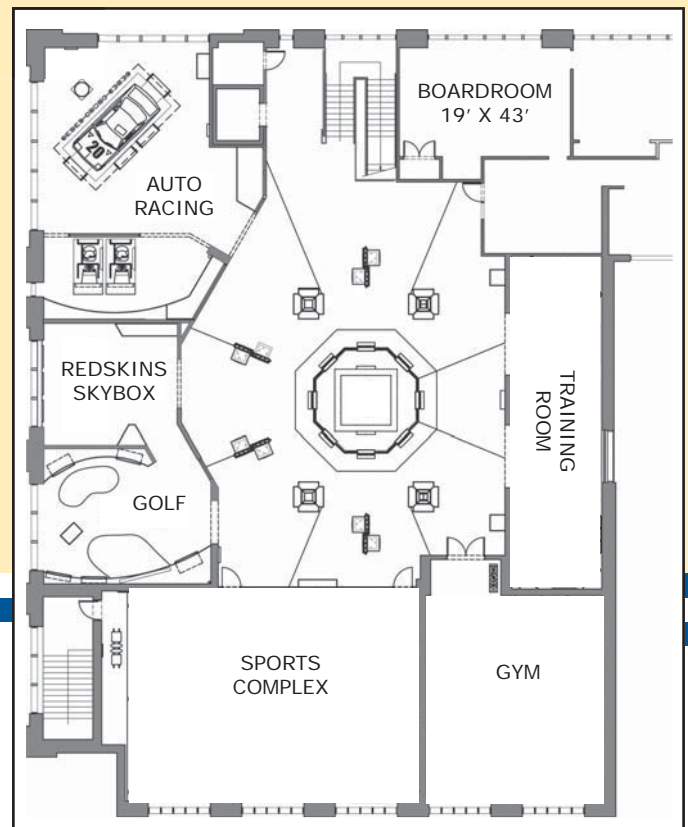

Details

THEME PARTIES

The Hall of Fame provides a colorful, contemporary backdrop for events of all kinds. When planning your next function, consider the following themes:

- Super Bowl, World Series, or championship party.
- "Pep rally" for your business.
- Campaign kickoff or victory party.
- College football tailgate.
- Team-building workshop.

FACILITY RENTALS INCLUDE:

- Exclusive use of the rented area.
- Access to all interactive exhibits.
- All guests' admission to the museum.
- On-site staff throughout your event.
- Housekeeping after your event.
- Use of the Hall of Fame's tables, chairs, & risers.

FOOD & BEVERAGE POLICIES

- A list of **Preferred Caterers** will be provided to you by event staff.
- You may use a caterer not included on this list; however, a fee may be applied.
- If alcohol will be served, an ABC license must be secured, either by you or your caterer, and should be posted throughout the event.
- No red wine is permitted.

PARKING



Safe and secure parking is conveniently located behind the Hall of Fame in the **Middle Street Parking Garage**. On weekends & after 6:00 p.m. on weekdays, parking is free. All other times, an hourly fee is collected by the City of Portsmouth Parking Authority. If you would prefer to cover your guests' parking expense, our event staff will gladly assist you.

YOUTH BIRTHDAY & TEAM PARTIES

Make your child's birthday or end-of-season team party one to remember! Have it at the Hall of Fame. To plan your party, contact the Museum Reservationist at **757-393-8031 ext. 21**. Parties are held on Saturdays & Sundays in the Classroom, and include admission, a meal & a party favor for each child.



We look forward to hosting you!